

Hand-Held Measuring Devices

A Passion for Precision



a passion for precision · passion pour la précision · pasión por la precisión · passione per la precisione · a passion for precision



www.handmessgeraete.info



Robust technology with a sophisticated design.

Precision and reliability all in one – engineered by professionals for professionals.

Measuring on the move



The highly demanding and complex measuring tasks of today can only be mastered with high-precision devices. The special requirements placed on hand-held measuring devices are the result of the spectrum of physical measurements that are to be measured, as well as the decisions that are based on this measured data. Architects, specialists and surveyors, engineers, climate experts and many other professionals bear the responsibility for people, technology, goods and processes. Whether investigating the temperature of a surface without contact, the dew point temperature of air or on walls, the moisture content of oil, air pressure or air flow, Lufft hand-held devices are easy to operate and – above all – precise!

The compact **E(economy)-Series** offers the most simple, intuitive handling and reliable measurement technology for small budgets. The thermo-hygrometer with its display and storage of threshold values, in addition to average values, operates with precision and is ideal for climate testing, as well as calculating absolute humidity and dew point. Optional accessories include filters for areas with high dirt levels – a metal grid filter for medium dirt protection or a stainless steel sinter filter for high dirt protection.

The E200 IR can also be used as a laser pyrometer for contact-free measurement of surface temperatures, including measurement position marking. It is ideally suitable for detecting thermal bridges.

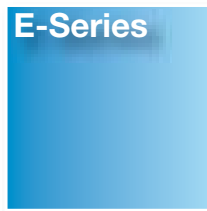

The **A(advanced)-Series** is the multi-talent in the measuring technology sector and therefore the ideal all-rounder. Hardly any other professional device on the market guarantees a flexibility comparable to that of the A1-SDI. This is due to its digital interface and the fact that the PT100 input for high-precision sensors allows the user to apply a variety of sensors. Instead of needing a multitude of measuring devices the professional only needs one.

The A1-SDI sensor library already offers a wide variety of sensors for temperature, humidity and air flow, and this library is continually being expanded. The new A-Series generation is also available with Bluetooth Technology making the wireless transfer of measured data to a laptop child's play.



The **C(omfort)-Series** with its large, illuminated display is the ideal hand-held measuring device for industry and air conditioning. Its robust housing and sensor technology stand for professional everyday use. The C-Series – with a total of 10 versions for varying measurement tasks – are regarded as, and rightly so, specialist devices for today's specialists. The C-Series includes the digital thermometer (C1XX), combined thermo-hygrometer (C2XX), precision air-/ differential pressure measuring device (C3XX), digital anemometer (C400) or the digital display device (C900) for analogue input signals. Unique in its class is the reference thermometer C101 with an accuracy of 0.02°C in the range -40°C...200°C!

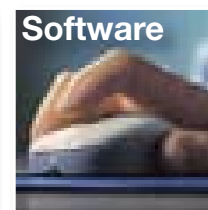

The **SmartGraph2-Software Package** is, in conjunction with the A-Series, a data recording system for the professional. SmartGraph runs on Windows and enables you to flexibly manage several measuring devices, whereupon the measured data is

automatically saved and filed into its respective calendar week. The user interface is clear and concise and offers a comprehensive monitoring of all acquired measured values – whether in a table format or graph. Zoom and print functions are obligatory and the software even documents in detail all violations of predefined threshold values. And best of all: the standard version of SmartGraph 2 is free of charge and can be downloaded from www.lufft.de.



Lufft's hand-held measuring device product range is comprehensive and can be implemented in a full spectrum of various application areas. By using the table below you will be able to get an overview of the most important device features. This will enable you to find the right device from the various series that best meets your needs. Take your time and compare the range of functions offered with those of competitors' products and you will discover that Lufft is in a class of its own.

Decisive for the various applications are first and foremost the physical measurements that need to be measured. For this purpose we have compiled a concise table to be used as a general overview. More detailed information regarding our measuring devices and connectable sensors can be found in the technical descriptions on the following pages.

Functions								
Functions of Lufft Measuring Devices								
Functions	E200	E200 IR	A1-SDI	C1XX	C2XX	C3XX	C400	C900
Thumb-wheel	x	x	x	x	x	x	x	x
Illuminated display			x	x	x	x	x	x
Universal analogue inputs								x
1 point calibration	x	x	x	x	x	x	x	x
1 and 2 point calibration			x	x	x	x		
°C/°F switchable	x	x	x	x	x			
Acoustic alarms		x						
Date/time			x	x	x	x	x	x
MIN/MAX/HOLD/Measurement value	x	x	x	x	x	x	x	x
Bluetooth data transfer			x					

Physical Measurements								
What you can measure with Lufft measuring devices – now and in the future.								
Physical Measurements	E200	E200R	A1 SDI	C1XX	C2XX	C3XX	C4XX	C9XX
Temperature								
Air temperature	x	x	x	x	x		x	
Surface temperature		x	x	x				
Infrared temperature (non-contact)		x						
Dew point temperature of the air	x	x	x		x			
Dew point temperature on walls		x						
Humidity								
Air humidity	x	x	x		x			
Absolute humidity	x	x	x		x			
Humidity measurement in oil			x					
Flow								
Air flow			x				x	
Pressure								
Absolute pressure						x		
Differential pressure						x		
Air pressure						x		
Standard signals								
Current (0/4...20mA)								x
Voltage (0...10V)								x

Reliable and Reasonably Priced.
For more precise temperature and humidity measurements, with dew point regulation included.

For a Good Entry Level
E-Series

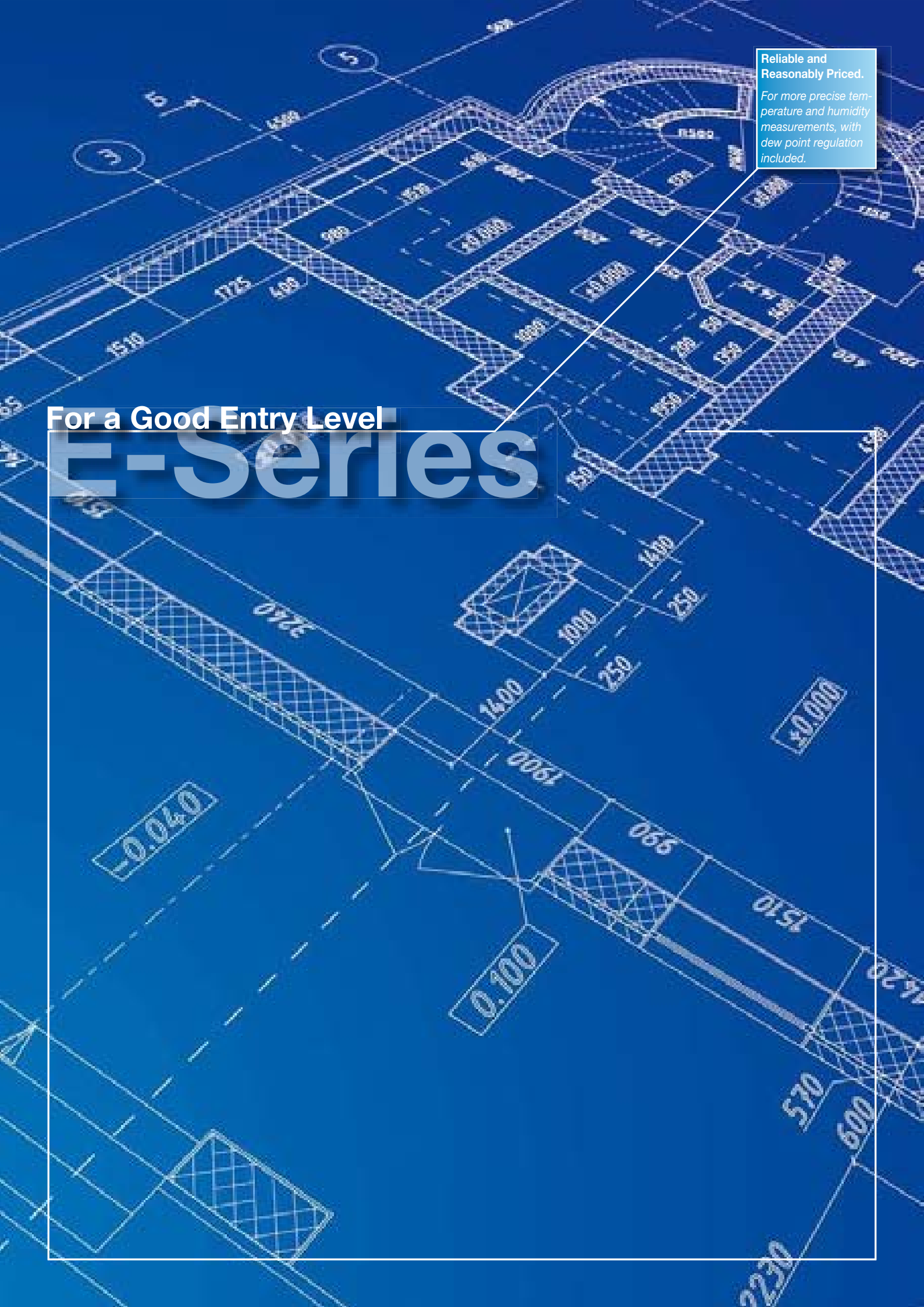

Climate Monitoring in Buildings



Hand-Held Device E200			Order No.
<p><i>Portable thermo-hygrometer with a fixed probe. Application areas: climate monitoring in buildings; climate control in control cabinets, museums and storerooms; dew point calculation; calculation of absolute humidity, Hold, MAX, MIN, Average value; single point calibration.</i></p>			5220.00
Technical data	Dimensions	175x48x25 mm	
	Weight	Approx. 200g	
	Functions	HOLD/MAX/MIN/AVG/Unit1/Unit2/CAL1/CAL2	
Temperature	Principle	NTC	
	Measuring range	-20... 50 °C	
	Accuracy	±0.4 °C (0... 40 °C), otherwise ±0.7 °C, + 1 Digit	
Relative humidity	Principle	Capacitive	
	Measuring range	5... 95 % RH	
	Accuracy	±3 % RH, + 1 Digit	
Accessories	Calibration solution 35 % RH		5120.035
	Calibration solution 50 % RH		5120.050
	Calibration solution 80 % RH		5120.080
	Metal grid filter for medium dirt protection		5120.210
	Stainless steel sinter filter for high dirt protection		5120.211
	Robust calibration block		5120.KAL
	Case for device E200		5120.BAG



Hand-Held Device E200 IR			Order No.
<p><i>With an additional infrared thermometer and laser pyrometer for the easy detection of thermal bridges in buildings – a must for all building professionals. Thermo-hygrometer or laser pyrometer – all depends on the application. In TH-mode the measuring device is equivalent to the E200, offering the user the same functions. In IR-mode the E200 IR is a laser pyrometer for contact-free measurement of surface temperatures with measurement position marking. In DP-mode dew point temperature and surface temperature are displayed simultaneously on the easy-to-read display. Wall surfaces can be checked and thermal bridges detected quickly with the aid of the alarm function. And alarm thresholds can be configured individually.</i></p>			5240.00
Technical data	Dimensions	175x48x25 mm	
	Weight	Approx. 200g	
	Functions	HOLD/MAX/MIN/AVG/Unit1/Unit2/CAL1/CAL2	
	Optical measurement	8:1	
Temperature	Principle	NTC	
	Measuring range	-20... 50 °C	
	Unit/Resolution	°C / 0.1 °C	
	Accuracy	±0.4 °C (0... 40 °C), otherwise ±0.7 °C, + 1 Digit	
Relative humidity	Principle	Capacitive	
	Measuring range	5... 95 % RH	
	Accuracy	±2 % RH	
Surface temperature	Principle	Thermopile	
	Measuring range	-20... 60 °C	
	Accuracy	±2 °C (Tobj > 0 °C, Tamb > 10 °C)	
Accessories	Calibration solution 35 % RH		5120.035
	Calibration solution 50 % RH		5120.050
	Calibration solution 80 % RH		5120.080
	Metal grid filter for medium dirt protection		5120.210
	Stainless steel sinter filter for high dirt protection		5120.211
	Robust calibration block		5120.KAL
	Case for device E200		5120.BAG



The multi-talented device on the measuring technology scene.
One device instead of several – universal and flexible thanks to its digital sensor interface.

All-in-One

A-Series

Without a doubt the A-Series represents the advanced technology in Lufft's measuring device product range – a specially advanced device generation using Bluetooth technology to transfer data to a laptop.



A complete package: the HKL-Set 9130 is specially engineered for the requirements in the areas of heating/air conditioning/ventilation to measure temperature, humidity and air flow.



Bluetooth technology not only ensures the connection of hands-free equipment of mobile phones, but is also used for industrial applications. Bluetooth operates on the unlicensed 2.4 GHz radio frequency bandwidth and is a short-range radio standard which is replacing cables predominantly in Personal Area Networks (PAN).

Bluetooth guarantees a standard, wireless, secure and low cost data transfer instead of simultaneously using several other proprietary standards such as infrared or serial communication.

Thanks to its integrated radio module for wireless data transfer, the A1-SDI Bluetooth from Lufft is able to send the latest measured values over a distance of up to 30 meters outdoors to a PC or laptop where they are then ready for further evaluation. Secure connections are provided for – in case of a possible transfer error/failure, an acoustic alarm warns the user.

The Windows compatible SmartGraph software is included in delivery and in addition provides a clear representation and simple compilation of all measured data. This evaluation software can display measured values in both tables and graphs

and possesses standard functions such as print and export, as well as zoom and scroll tools for specific, graphical analysis.

If your computer does not have an integrated Bluetooth module, we recommend you purchase the USB Bluetooth adapter CN-521 from SiteCom.

The A-Series universal measuring devices are able to present various measured values on their display due to the connection of different SDI sensors. These sensors calculate physical measurements such as absolute humidity, dew point or air flow velocity and transfer the data to the measuring device. In addition to this, all calibration data is stored directly in the SDI sensor. Sensor recognition occurs automatically as soon as the device is turned on and users are also spared complicated menu navigation or the error-prone set-up of the device.

Play it safe and use the A-Series from Lufft.

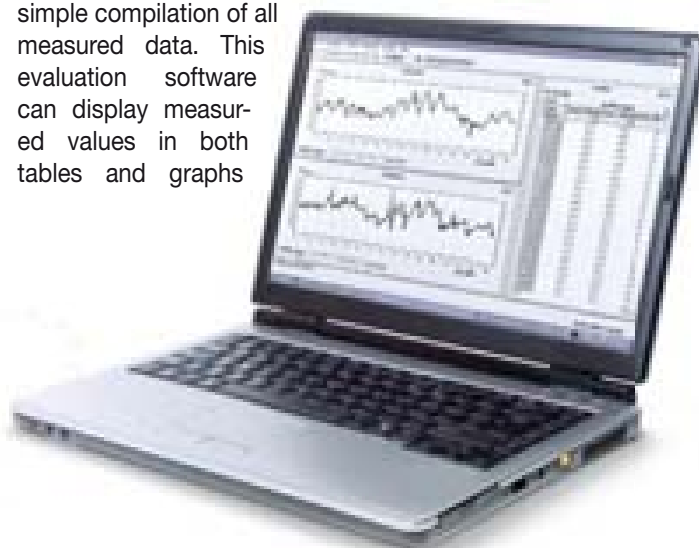



Universal Measuring Device A1-SDI

Precision and flexibility at a reasonable price. The all-round measuring device for professional applications – portable and robust. Instead of focusing on optional storage modules or attachable printers which cause a hand-held measuring device to become bulky and unnecessarily expensive, we at Lufft have realised a much more practical concept that takes its form in the A1-SDI. Soon, today's technicians will be armed with laptops for their measurement campaigns and these can be implemented as external storage units by using the Bluetooth version of the A1-SDI. This means that printouts can be carried out in the comfort of an office and not in the awkward environment of a boiler room.



Hand-Held Device A1-SDI		Order No.	
<i>Multi-talented measurement technology with digital sensor interface and PT100 input for temperature measurement – one measuring device for a multitude of measuring tasks. Excellent readability, illuminated display, Hold, MAX, MIN, Average value. Automatic switch-off function, single point calibration. THUMB-WHEEL operation, real-time clock.</i>			
Hand-Held Device A1-SDI		9130.00N	
Technical data	Dimensions	147x85x37 mm	
	Temperature	Principle	PT100 (3 wires)
		Measuring range	-200 ... 500 °C
		Accuracy	±0.5 °C (without sensors)
Accessories for both devices	Case for A1-SDI and 2 sensors	9130.CAS	
	Calibration solution 35 % RH	5120.035	
	Calibration solution 50 % RH	5120.050	
	Calibration solution 80 % RH	5120.080	
	Robust calibration block	5120.KAL	
	Screw-in 4-pole connector for PT100 individual sensors	3120.50	
	Extension cable for sensor, 2 m	8152.KAB	
Hand-Held Device A1-SDI Bluetooth		9130.BT	
Accessories	Bluetooth USB Adapter Sitecom CN-521	9130.PCA	



PT100 Surface Sensor

PT100 Temperature Sensors for A1-SDI



PT100 surface sensor (only for 9130.00N)			Order No.
PT100 Class B in accordance with DIN EN 60751. Application area: flat, smooth, metallic surfaces.			3120.60
Technical data	Measuring range	-50 ... 400 °C	
	Response time t90	Approx. 30s	
	Cable length	Approx. 1 m, PUR-lead and handle to be used up to 80 °C	
	Dimensions	155 x 4.5 mm	

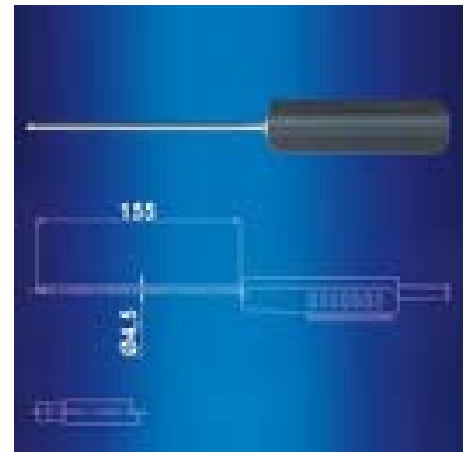

PT100 Plunge Sensor, Short (only for 9130.00N)			Order No.
PT100 Class B stainless steel protective tube. Application area: solid, liquid and powdery mediums.			3120.51
Technical data	Sensor type	PT100 Cl. B in stainless steel protective tube	
	Measuring range	-40 ... 400 °C	
	Response time	10s	
	Cable length	Approx. 1 m, PUR-lead and handle to be used up to 80 °C	
	Dimensions	150 x 4 mm	

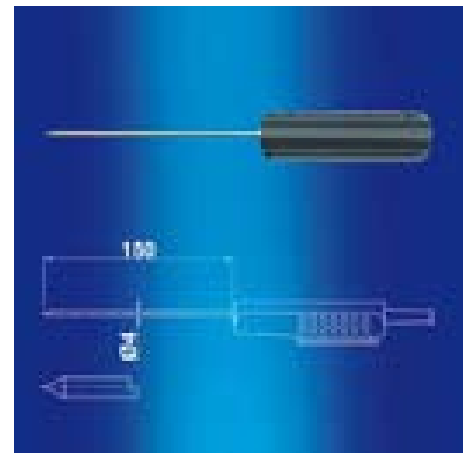

PT100 Plunge Sensor, Short			Order No.
PT100 Plunge Sensor, short. Class A in stainless steel protective tube. Application area: Gas, liquid and powdery mediums.			3120.52
Technical data	Sensor type	PT100 Cl. A in stainless steel protective tube	
	Measuring range	-40 ... 400 °C	
	Response time	10s	
	Cable length	Approx. 1 m, PUR-lead and handle to be used up to 80 °C	
	Dimensions	150 x 3 mm	

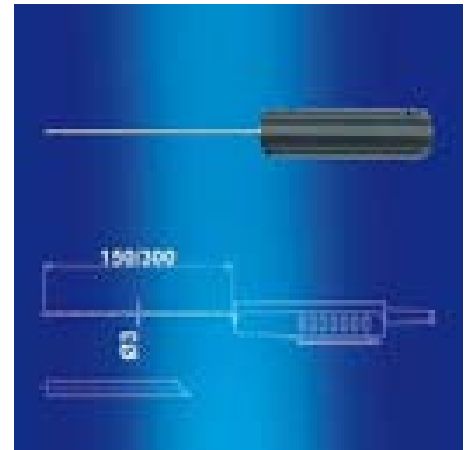

PT100 Plunge Sensor, Long			Order No.
Technical data	Dimensions	300 x 3 mm	3120.53

PT100 Plunge Sensor, Long (only for 9130.00N)			Order No.
PT100 1/10 DIN B (at 0°) in stainless steel protective tube. Application area: Gas, liquid and powdery mediums.			3120.54
Technical data	Measuring range	-40 ... 400 °C	
	Response time	10s	
	Cable length	Approx. 1 m, PUR-lead and handle to be used up to 80 °C	
	Dimensions	300 x 4 mm	

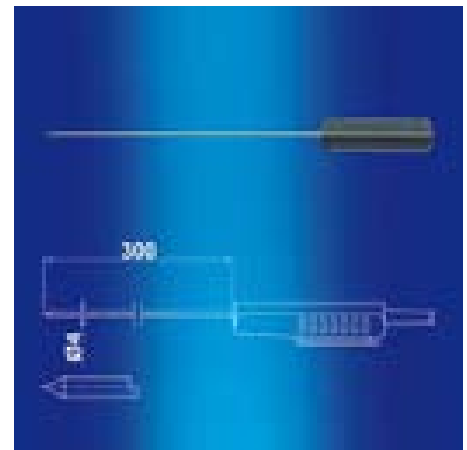



PT100 Combined Temperature/Humidity Sensors

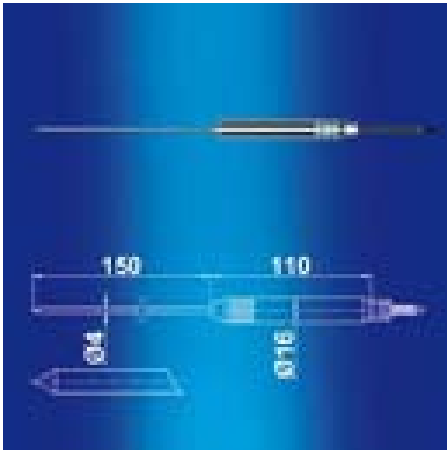

PT100 Plunge Sensor, Short (only for 9130.00N)			Order No.
PT100 Class A in a stainless steel protection tube. Application area: solid, liquid and powdery mediums.			3120.55
Technical data	Measuring range	-40 ... 400 °C	
	Response time	10s	
	Cable length	Approx. 1 m, PUR-lead and handle to be used up to 80 °C	
	Dimensions	150 x 4 mm	

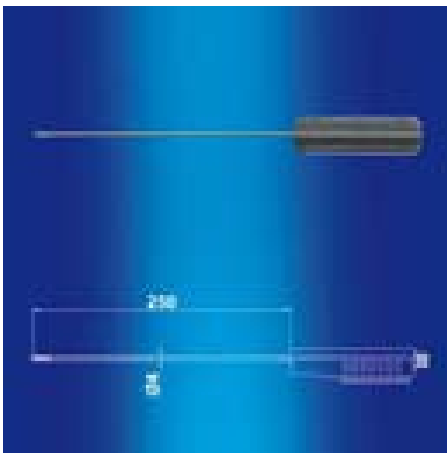

Temperature/Humidity Sensor with 4mm diameter (for 9130.00N and 9130.BT)			Order No.
Combined Temperature/Humidity Sensor.			9130.52
Technical data	Dimensions	Length 250 mm, Ø 4 mm	
	Relative humidity	Measuring range	
Temperature	Accuracy	±2 % (0 ... 90 %), ±3 % (90 ... 100 %) RH	
	Principle	PT1000 (tolerance class B, DIN EN 60751)	
	Measuring range	-40 ... 100 °C	
	Accuracy	±0.2 °C at 20 °C, otherwise ±0.7 °C	

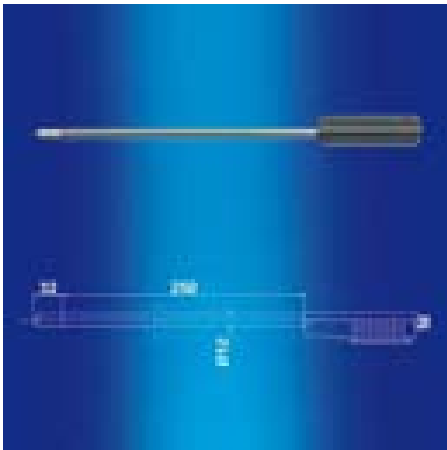

High Temperature Temperature/Humidity Sensor (for 9130.00N and 9130.BT)			Order No.
Combined High Temperature Temperature/Humidity Sensor.			9130.53
Technical data	Dimensions	Length 250 mm, Ø 12 mm	
	Relative humidity	Measuring range	
Temperature	Accuracy	±2 % (0 ... 90 %), ±3 % (90 ... 100 %) RH	
	Principle	PT1000 (tolerance class A, DIN EN 60751)	
	Measuring range	-40 ... 180 °C	
	Accuracy	±0.2 °C at 20 °C, otherwise ±0.7 °C	

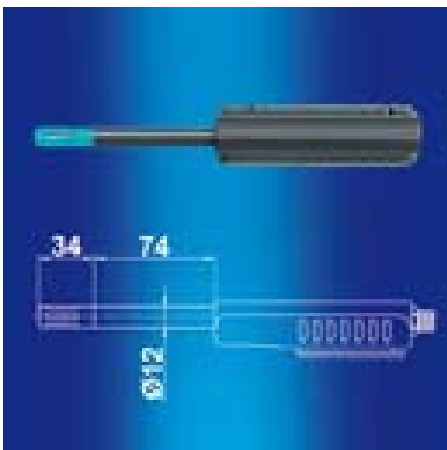

Low Cost Temperature/Humidity Sensor (for 9130.00N and 9130.BT)			Order No.
Low Cost Combined Temperature/Humidity Sensor.			9130.54
Technical data	Dimensions	Length 74 mm, Ø 12 mm	
	Relative humidity	Measuring range	
Temperature	Accuracy	±2 % (0 ... 90 %), ±3 % (90 ... 100 %) RH	
	Principle	NTC	
	Measuring range	-20 ... 70 °C	
	Accuracy	±0.2 °C at 20 °C	

Further information about our products can be found on our website www.handmessgeraete.info and www.lufft.de

Flow and Temperature Sensors Moisture Measurement in Oil



Air Flow/Temperature Sensor 0...2m/s (for 9130.00N and 9130.BT)			Order No.
Combined Flow/Temperature Sensor 0...2 m/s.			6120.51
Technical data	Dimensions	Length 200 mm, Ø 6 mm	
Flow	Measuring range	0...2 m/s	
	Accuracy	20 °C, 45 % RH, 1013 hPa: ±(0.04 m/s + 1 % of value)	
Temperature	Measuring range	-20...70 °C	
	Accuracy	±0.7 °C within the range of 0...50 °C and v>0.5 m/s	

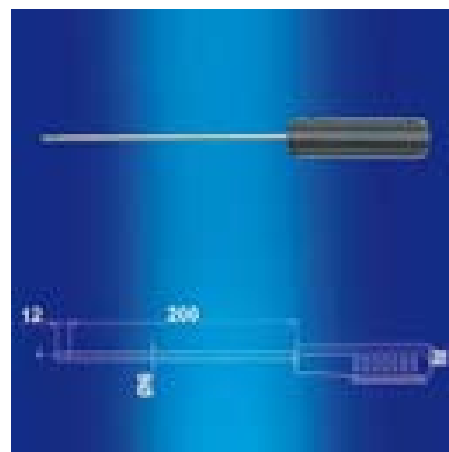

Air Flow/Temperature Sensor 0...20 m/s (for 9130.00N and 9130.BT)			Order No.
Combined Flow/Temperature Sensor 0...20 m/s.			6120.52
Technical data	Dimensions	Length 200 mm, Ø 6 mm	
Flow	Measuring range	0...20 m/s	
	Accuracy	20 °C, 45 % RH, 1013 hPa: ±(0.2 m/s + 2 % of value)	
Temperature	Measuring range	-20...70 °C	
	Accuracy	±0.7 °C within the range of 0...50 °C and v>0.5 m/s	

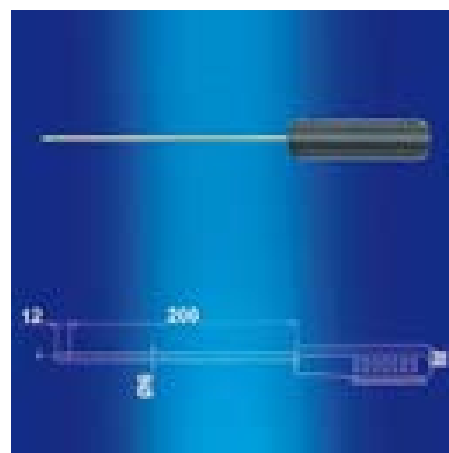

Low Cost Flow/Temperature Sensor 0...20 m/s (for 9130.00N and 9130.BT)			Order No.
Low Cost Combined Flow/Temperature Sensor 0...20 m/s.			6120.53
Technical data	Dimensions	Length 200 mm, Ø 12 mm	
Flow	Measuring range	0...20 m/s	
	Accuracy	20 °C, 45 % RH, 1013 hPa: ±(0.2 m/s + 3 % of measurement)	
Temperature	Measuring range	-20...70 °C	
	Accuracy	±1 °C within the range of 0...50 °C and v>0.5 m/s	

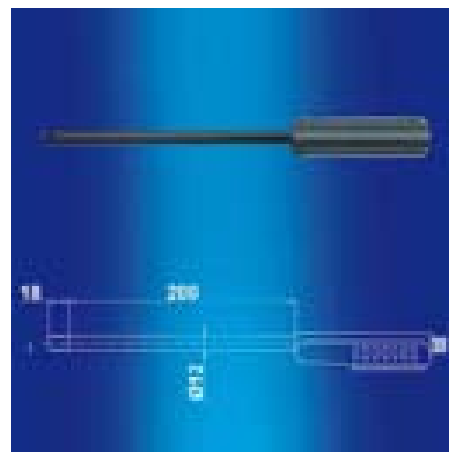

Water-in-Oil Sensor (for 9130.00N and 9130.BT)			Order No.
Sensor for moisture measurements in oil stating the absolute in ppm or relative water content aw. Sensor is based on a long-term stable, chemically resistant capacitive sensor. The measurement values that can be selected are: water activity (AW), temperature (T) and calculated water content in ppm for mineral transformer oil. For non-mineral transformer oils, the device can be adapted by inputting the oil-specific parameters of the respective oil.			9130.60
Technical data	Dimensions	Length approx. 200 mm, Ø 12 mm	
Water activity	Measuring range	0...1 aw	
	Accuracy	±0.02 aw (0...0.9 aw)	
Temperature	Principle	PT1000 (tolerance class A, DIN EN 60751)	
	Measuring range	-40...180 °C	
	Accuracy	±0.2 °C (at 20 °C)	



When it comes to evaluation have the works!
With the aid of powerful software, hand-held measuring devices are turning into archives.

Wireless Transfer, Storage and Analysis of Measured Values

Smart-Graph2

*The combination is the decisive factor: Lufft's SmartGraph2 software
– the digital library for all your measurement campaigns.*

Graphical Representation

This enables the user to have a quick overview of all measuring processes. No matter whether you need a 12 month summary or a detailed representation of a 10 minute period, the software is easy-to-use and comes with zoom function.

Violation of Threshold Values

Users are able to set upper and lower threshold value parameters per measuring channel. By means of graphical representation, critical time periods can be quickly screened.

Recording Function (PC)

With a connection to a PC, measured data can be recorded online and displayed.

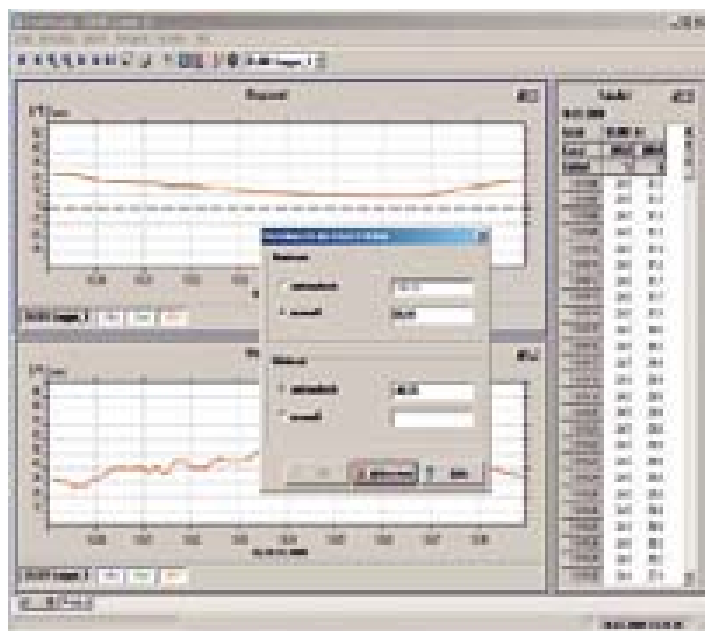
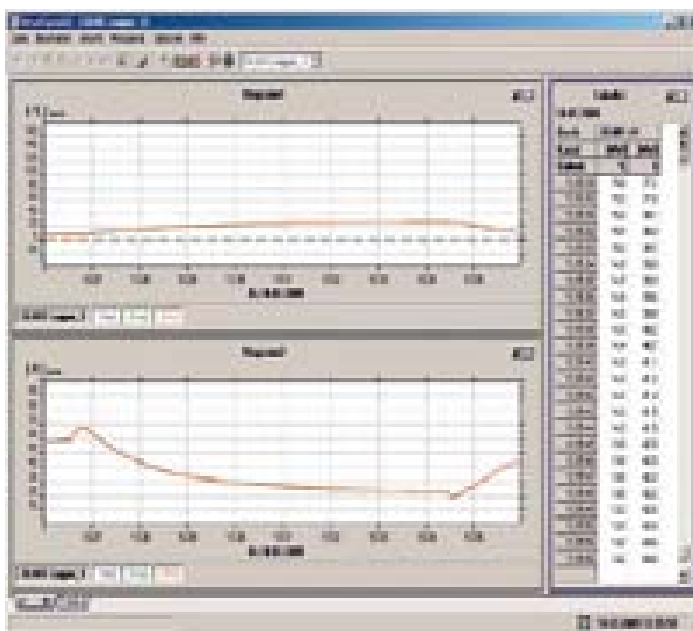
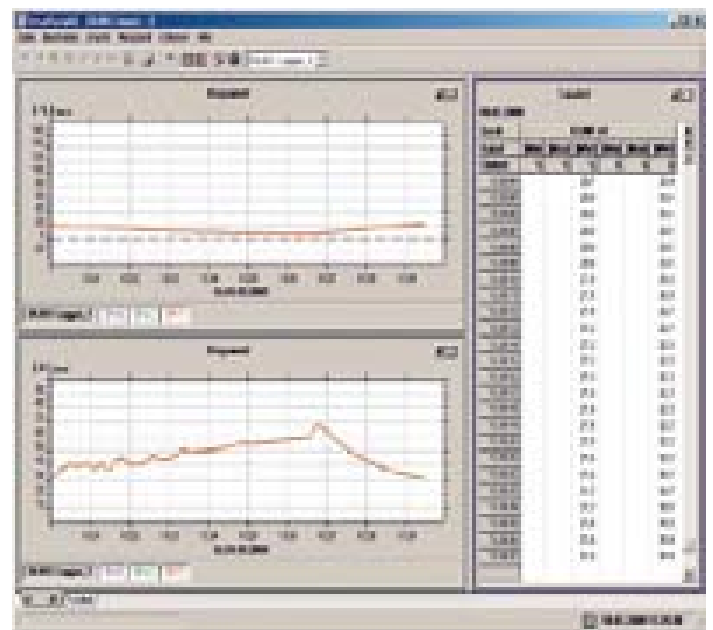
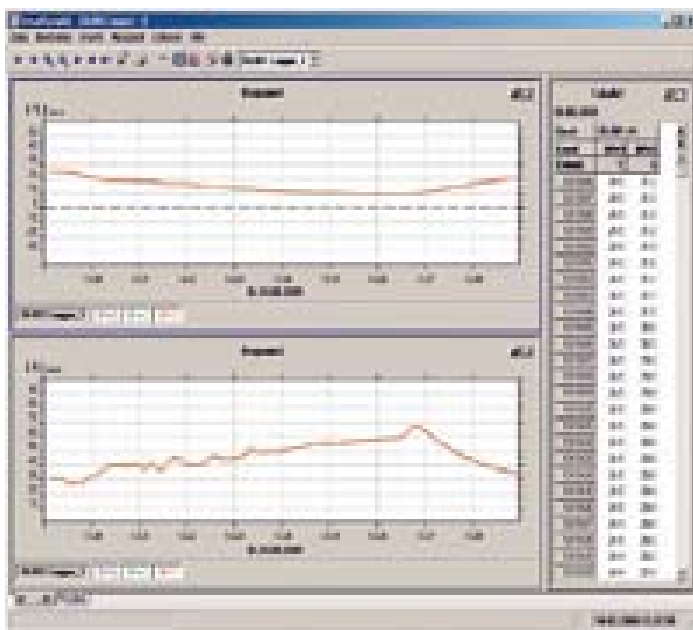



Set for Heating/Air Conditioning/Ventilation

The complete set is engineered especially for measuring tasks related to air conditioning. The set comes in a robust plastic case and in addition to the A1-SDI Measuring Device includes: a combined temperature/humidity sensor, a flow sensor, as well as a calibration block and the necessary calibration fluid for the calibration of moisture measurements.

The sensors can also be delivered with DKD or ISO certificates; and of course the A1-SDI is able to support all of the sensors from the product range in order to give you more scope in future application areas.

HACV-Kit (Heating/Air Conditioning/Ventilation)	Order No.
<p>Set with all necessary components for measurement tasks related to air conditioning: for measuring temperature, relative humidity, air flow. Includes calibration set.</p> <p>Set HACV includes:</p> <ul style="list-style-type: none"> - A1-SDI Measuring Device (9130.Set) - Temperature/humidity sensor (9130.54) - Flow sensor (6120.53) - Solid calibration block (5120.KAL) - Calibration liquid 50% RH (5120.050) - Case for A1-SDI, 2 sensors and calibration block (9130.CAS) 	9130.Set



Accuracy of PT100 Sensors and Thermocouples



The measurement principle of the thermocouple is based on the effect discovered by Seebeck, whereby a voltage arises at the ends of two wires of different materials when the temperature at the junction (point) of the two materials is different to that of the temperature of the measuring device terminals. Depending on the application, our measuring devices are equipped with Class 1 or 2 thermocouples. These thermocouples offer the coverage of a large measurement range (just short of 1,800 °C) in combination with a fast reaction time.

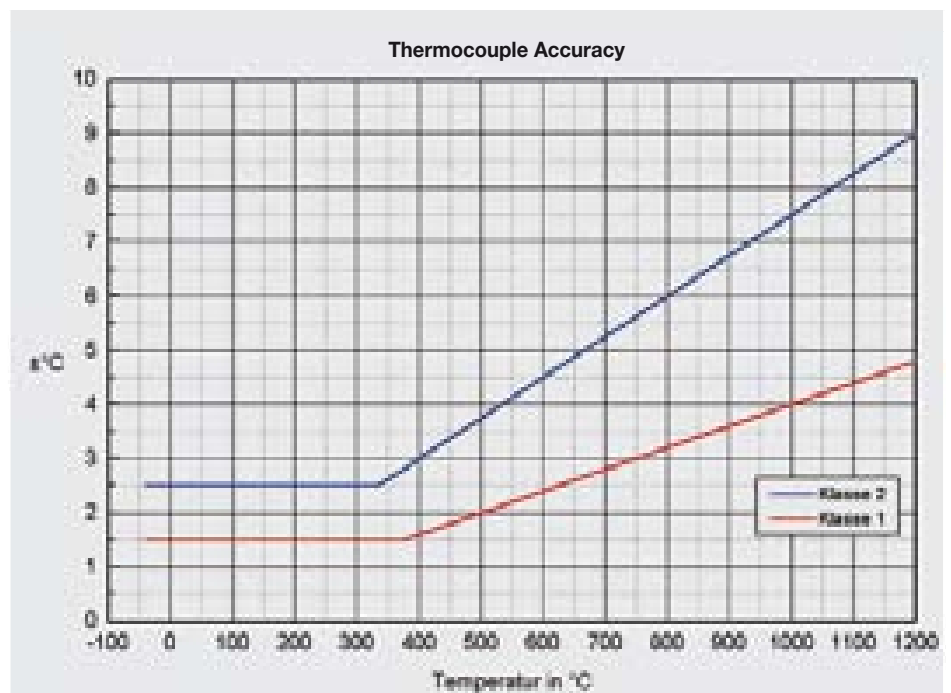

Our resistance sensors (PT100) are more accurate than thermocouples, but also slower. They are also divided into two accuracy classes (Class A: $0.15 + 0.002 |t|$ and Class B: $0.30 + 0.005 |t|$) – see diagram (both refer to °C).

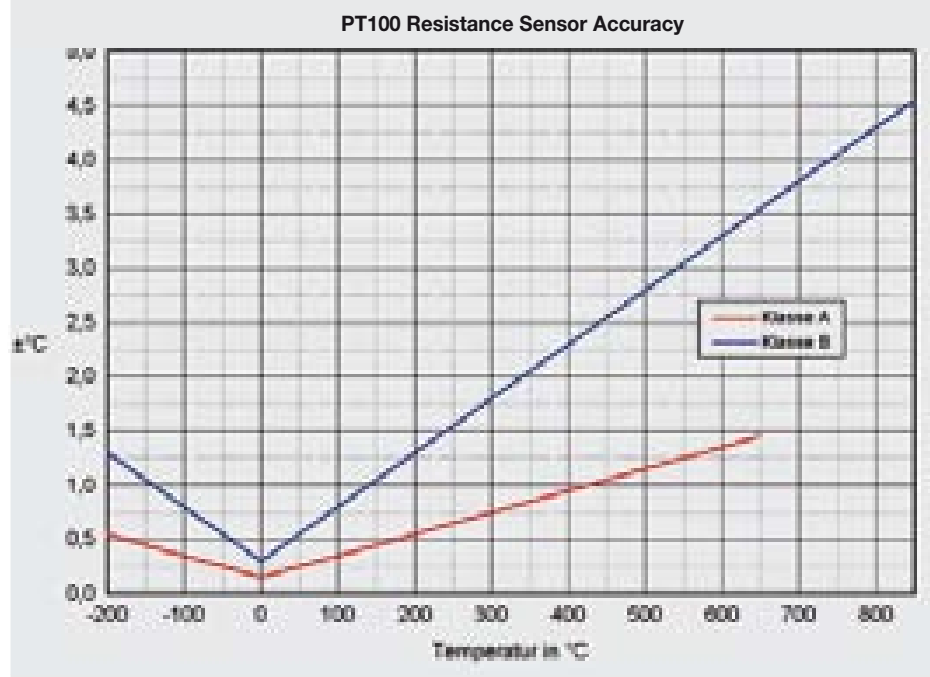

Specialists suitable
for all applications.

*Full flexibility when
measuring various
physical measure-
ments.*

Flexibility is the Name of the Game

C-Series

Reference Thermometer C101



The benchmark – whenever it is a question of precise temperature measurements, then a reference device is a must, as it is generally 10 times more precise than the test device. The C101 was developed precisely for its role as a calibration device with an accuracy that can be traced back to the official norm. To accomplish this, the thermometer is strictly measured and the characteristics are individually adjusted for each device. Only by doing this can an overall accuracy be achieved – for the entire measuring range!

Reference Thermometer C101 (Accuracy of 0.02°C) Temperature			Order No.
<p><i>The C101 Reference Thermometer is unique in its class with an accuracy of 0.02°C in the range -40°C...200°C. This is achieved by means of high-quality, coiled, glass-sealed PT100 sensors and precision electronics with a 24 bit analogue/digital converter. Both the sensor and the electronics are pre-aged in an intricate process and in this way achieve excellent long-term stability.</i></p>			3120.SET
Technical data	Dimensions (C101)	147 x 85 x 37 mm	
	Included in delivery	Sensor, case, battery, factory certificate	
	Functions	HOLD/MAX/MIN/AVG/DATE/TIME/AutoOFF, CAL, POLY-CAL/°C, °F/display illumination	
	Dimensions	sensor: 300 x 4 mm	
	Cable length	Approx. 2 m, PUR cable and handle can be used up to 80°C	
	Application area	Gas, liquid and powdery mediums	
	Response time	10 s	
	Temperature coefficient, electronics	± 1 mK/K	
	Resolution	0.01 °C (- 100 ... 200 °C), otherwise 0.1 °C	
	Measuring range (device)	-200 ... 500 °C	
Temperature	Principle	PT100 (4 wire)	
	Measuring range	-150 ... 450 °C	
	Accuracy	± 0.01 °C (bei 0 °C), ± 0.02 °C (-40 ... 200 °C), +1 Digit	
Accessories	DKD Certificate with 5 temperature points		DKD.1T204

Further information about our products can be found on our website www.handmessgeraete.info and www.lufft.de



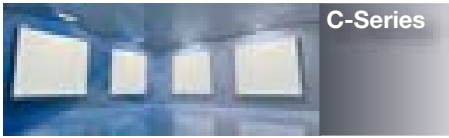

Universal Display Device for Voltage and Current

The C900 is a universal display device that can conform to your requirements and contains an A/D converter which can be individually programmed and combined with virtually any sensor.

If, for example, there are faults in machinery or machinery breaks down, then a diagnostician is required. Only with the help of a fast display device like the C900 can short-term occurring peaks be registered, and the device's smallest sampling rate amounts to 1 millisecond. In combination with various industrial sensors for voltage and current you can clearly see the flexibility of the C900 from Lufft; set up in a few simple steps, it is able to deliver to its large display the digital conversion of all types of physical measurements.

Hand-Held Device C900 Current/Voltage	Order No.
<p><i>Display device for all 0/4...20mA and 0...10V sensors with a built-in sensor feed and peak value recording in 'Fast' mode:</i></p> <ul style="list-style-type: none"> - For 0/4...20mA and 0...10V measurements in 2/3 wire - Built-in 20V feed for 4...20mA sensors - 'Fast' mode with 1ms sampling rate, display MAX/MIN value - Free sensor scaling - Excellent readability (illuminated display) - Adjustable automatic switch-off function - Built-in real-time clock - Functions: Hold/MAX/MIN/Average value - Unique THUMB-WHEEL operation, select and execute all functions with your thumb - Single point calibration 	
Hand-Held Device C900 Current/Voltage	9120.00

Further information about our products can be found on our website www.handmessgeraete.info and www.lufft.de



Digital Thermometers

PT100 Surface Sensor



Hand-Held Device C100 Temperature			Order No.
PT100 laboratory thermometer with 0.01°C resolution. High-precision measurement for use in industry and the laboratory. Excellent readability (illuminated display), automatic switch-off function, single point calibration, PT100 polynomial calibration, THUMB-WHEEL operation.			3120.00
Technical data	Dimensions	147 x 85 x 37 mm	
	Weight	Approx. 400 g	
	Functions	HOLD/MAX/MIN/AVG/DATE/TIME/AutoOFF, CAL, POLY-CAL /°C, °F/display illumination	
Temperature	Principle	PT100 (4 wire)	
	Measuring range	-200 ... 500 °C	
	Accuracy	± 0.1 °C (-100 ... +200 °C), otherwise ± 0.2 °C (without sensor)	
Accessories	Carrying case for device and accessories		3120.CAS



C100, 1 channel, PT100

Hand-Held Device C110 Temperature			Order No.
Hand-Held Device C110			3120.10
Technical data	Dimensions	147 x 85 x 37 mm	
	Weight	Approx. 400 g	
	Functions	HOLD/MAX/MIN/AVG/DATE/TIME/AutoOFF, CAL, POLY-CAL /°C, °F/display illumination	
Temperature Channel 1	Principle	Pt100 (4 wire)	
	Measuring range	-200 ... 500 °C	
	Accuracy	± 0.1 °C (-100 ... +200 °C), otherwise ± 0.2 °C (without sensor)	
Temperature Channel 2	For Thermocouple-sensor Type K/J/N/E/R/S/T		
Accessories	Carrying case for device and accessories	3120.CAS	



C110, 2 channels, PT100 + TC (thermocouple)

Hand-Held Device C120 Temperature			Order No.
Hand-Held Device C120			3120.20
Technical data	Dimensions	147 x 85 x 37 mm	
	Weight	Approx. 400 g	
	Functions	HOLD/MAX/MIN/AVG/DATE/TIME/AutoOFF, CAL/°C, °F/display illumination	
Temperature Channel 1	For Thermocouple-sensor Type K/J/N		
Temperature Channel 2	For Thermocouple-sensor Type E/R/S/T		
Accessories	Carrying case for device and accessories		3120.CAS



C120, 2 channels, 2 x TC (thermocouple)

PT100 Surface Sensor			Order No.
PT100 Class B in accordance with DIN EN 60751. Application area: flat, smooth, metallic surfaces.			3120.60
Technical data	Measuring range	-50 ... 400 °C	
	Response time t90	Approx. 30 s	
	Cable length	Approx. 1 m, PUR-lead and handle to be used up to 80 °C	
	Dimensions	150 x 4.5 mm	

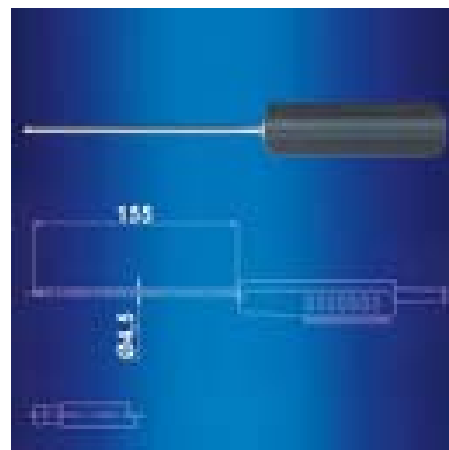



PT100 Temperature Sensors for C100/110

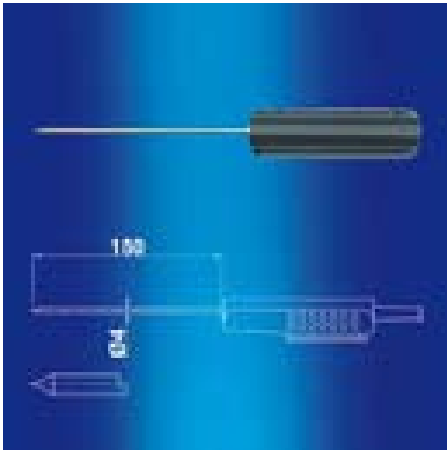

PT100 Plunge Sensor, Short		Order No.
PT100 Class B in a stainless steel protection tube. <i>Application area: solid, liquid and powdery mediums.</i>		3120.51
Technical data	Sensor type	PT100 Cl. B in stainless steel protection tube
	Measuring range	-40 ... 400 °C
	Response time	10 s
	Dimensions	150 x 4 mm
	Cable length	Approx. 1 m, PUR-lead and handle to be used up to 80 °C

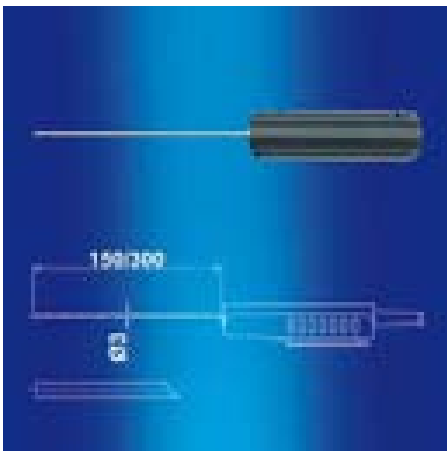

PT100 Plunge Sensor, Short		Order No.
PT100 Plunge Sensor, Short. Class A in a stainless steel protection tube. <i>Application area: gas, liquid and powdery mediums.</i>		3120.52
Technical data	Sensor type	PT100 Cl. A in stainless steel protection tube
	Measuring range	-40 ... 400 °C
	Response time	10 s
	Cable length	Approx. 1 m, PUR-lead and handle to be used up to 80 °C
	Dimensions	150 x 3 mm
PT100 plunge sensor, long		3120.53
Technical data	Dimensions	300 x 3 mm

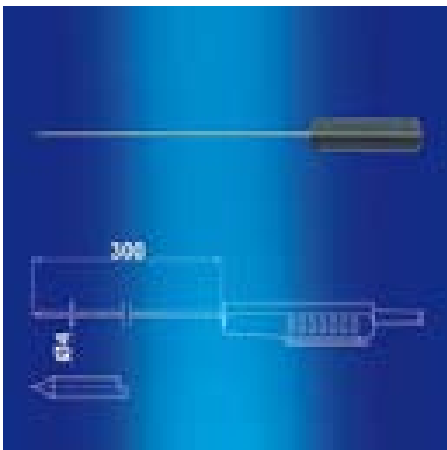

PT100 Plunge Sensor, Long		Order No.
PT100 1/10 DIN B (at 0°C) in a stainless steel protection tube. <i>Application area: gas, liquid and powdery mediums.</i>		3120.54
Technical data	Measuring range	-40 ... 400 °C
	Response time	10 s
	Cable length	Approx. 1 m, PUR-lead and handle to be used up to 80 °C
	Dimensions	300 x 4 mm

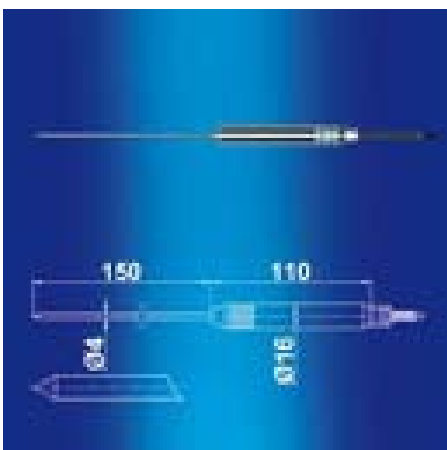

PT100 Plunge Sensor out of Stainless Steel for Foodstuffs		Order No.
PT100 1/10 DIN B (at 0°C) in a stainless steel protection tube. <i>Application area: gas, liquid and powdery mediums.</i>		3120.55
Technical data	Measuring range	-40 ... 400 °C
	Response time	10 s
	Cable length	Approx. 1 m, PUR-lead and handle to be used up to 80 °C
	Dimensions	150 x 4 mm

PT100 Thermocouple Sensors (TC)



Thermocouple Plunge Sensor, Short, for Temperatures up to 400°C			Order No.
Type K, Cl. 1, VA protection tube.			3120.71
Application area: liquid and powdery mediums.			
Technical data	Measuring range	-50 ... 400 °C	
	Response time	10 s	
	Dimensions	150 x 3 mm	
	Cable length	Approx. 1 m, lead and handle to be used up to 80 °C	

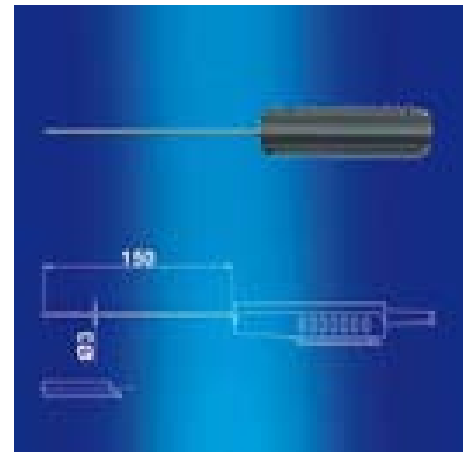

Mineral Isolated Thermocouple Plunge Sensor, Short, for Temperatures up to 1,100°C			Order No.
Type K, Cl. 1, Inconel.			3120.72
Application area: liquid and powdery mediums.			
Technical data	Sensor type	Type K, Cl. 1, Inconel	
	Measuring range	-50 ... 1,100 °C	
	Response time	10 s	
	Dimensions	150 x 3 mm	
	Cable length	Approx. 1 m, lead and handle to be used up to 80 °C	

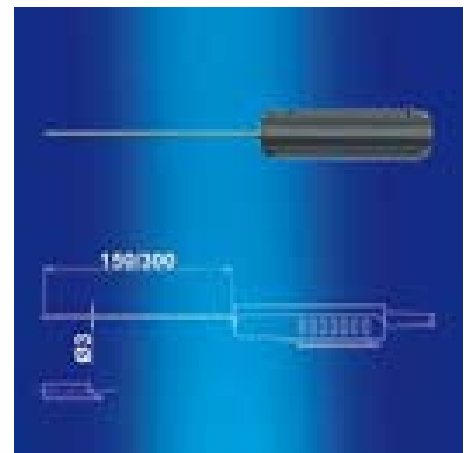

Quick Thermocouple Sensor, Short, for Temperatures up to 1,100°C			Order No.
Fast Thermocouple Sensor, Short. Type K, Cl. 1, Inconel.			3120.73
Application area: liquid and powdery mediums.			
Technical data	Measuring range	-50 ... 1,100 °C	
	Response time	4 s	
	Dimensions	150 x 1.5 mm	
	Cable length	Approx. 1 m, lead and handle to be used up to 80 °C	
Mineral Isolated Thermocouple Plunge Sensor, Long, for Temperatures up to 1,100°C			3120.74
Technical data	Dimensions	300 x 3 mm	

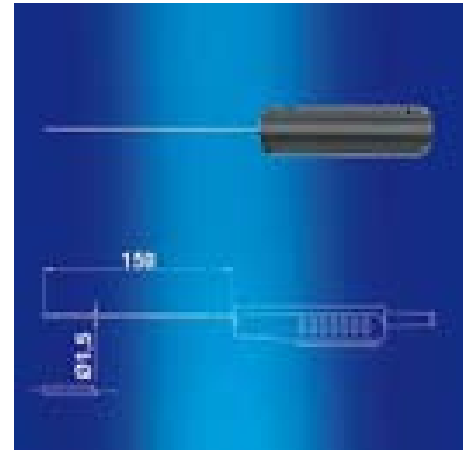

Thermocouple Surface Sensor, for Temperatures up to 600°C			Order No.
Type K, Cl. 1, VA protection tube with nickel contact.			3120.75
Application area: solid mediums.			
Technical data	Measuring range	-50 ... 600 °C	
	Response time	20 s	
	Dimensions	150 x 3 mm / 6 mm (L x d1 / d2)	
	Cable length	Approx. 1 m, lead and handle to be used up to 80 °C	

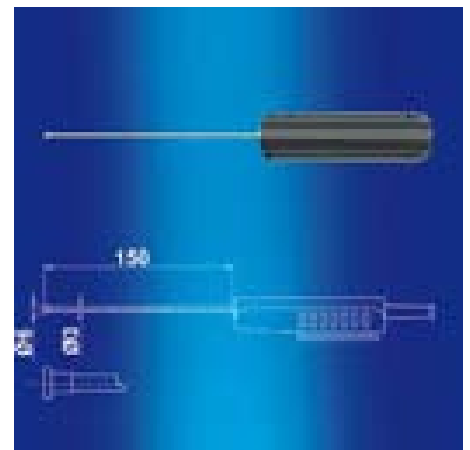

Further information about our products can be found on our website www.handmessgeraete.info and www.lufft.de



Thermocouple Sensors (TC) for C110/120

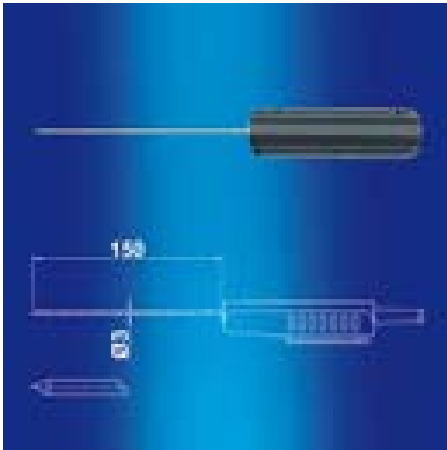

Thermocouple Needle Probe for Medium-Hard Materials			Order No.
<i>Thermocouple Needle Probe for Medium-Hard Materials with 2m spring cable for temperatures up to 400°C. Type K, Cl. 1, VA protective tube. Application area: solid mediums.</i>			3120.76
Technical data	Measuring range	- 100 ... 400 °C	
	Response time	10s	
	Dimensions	150x3mm	
	Cable length	Approx. 1 m, lead and handle to be used up to 80 °C	

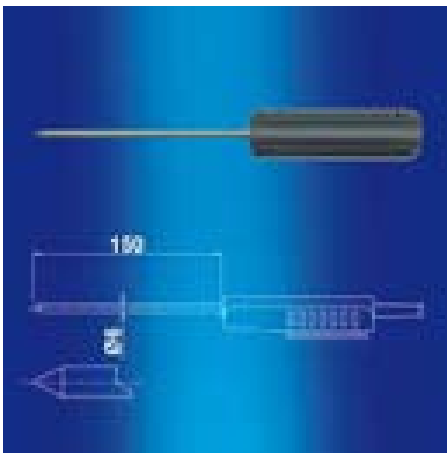

Stable Thermocouple Needle Probe, with 2m Spring Cable for Temperatures up to 400°C			Order No.
<i>Type K, Cl. 1, VA protection tube. Application area: solid mediums.</i>			3120.77
Technical data	Measuring range	- 100 ... 400 °C	
	Response time	10s	
	Dimensions	150x6mm	
	Cable length	Approx. 1 m, lead and handle to be used up to 80 °C	

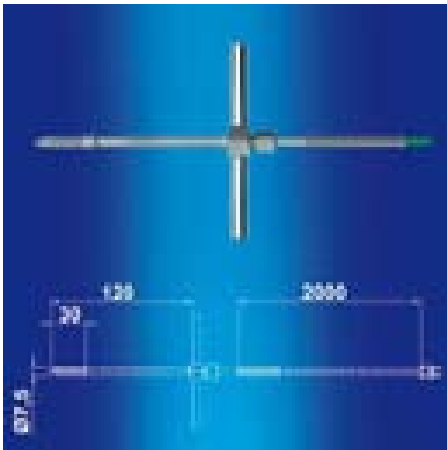

Screw-In Thermocouple Sensor for Frozen Foodstuffs for Temperatures up to 200°C			Order No.
<i>Screw-In Thermocouple Sensor (no drilling necessary), for Temperatures up to 200°C. Type K, Cl. 1, VA protection tube with nickel contact. Application area: solid mediums.</i>			3120.78
Technical data	Measuring range	- 100 ... 200 °C	
	Response time	25s	
	Dimensions	120x6mm	
	Cable length	Approx. 1 m, lead to be used up to 80 °C	

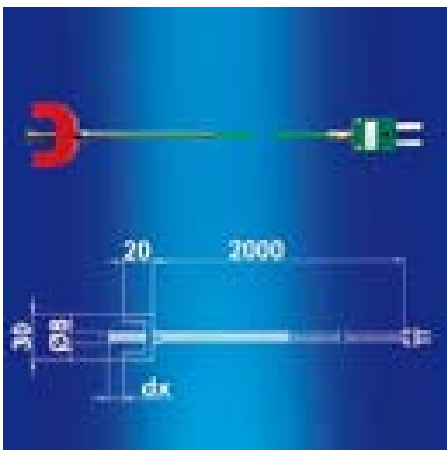

Magnetic Thermocouple Surface Sensor			Order No.
<i>Magnetic Thermocouple Surface Sensor with spring connection of thermocouple and 2m PTFE cable (Teflon) for temperatures up to 150°C. Type K, Cl. 1. Application area: solid mediums.</i>			3120.79
Technical data	Measuring range	- 50 ... 150 °C	
	Cable length	Approx. 2 m	

Further information about our products can be found on our website www.handmessgeraete.info and www.lufft.de

Thermo-Hygrometers



Hand-Held Device C200 Temperature/Humidity			Order No.
<p><i>Thermo-hygrometer with fixed sensor. Application area: climate monitoring in buildings; climate control in ventilation ducts, control cabinets, storerooms and museums; dew point calculation; calculation of absolute humidity. Excellent readability, illuminated display, Hold, MAX, MIN, Average value, automatic switch-off function, single point calibration (temperature), double point calibration (RH), THUMB-WHEEL operation, real-time clock, °C/°F switchable.</i></p>			
Hand-Held Device C200			5120.00
Technical data	Dimensions	147 x 85 x 37 mm	
	Weight	Approx. 400g	
	Functions	HOLD/MAX/MIN/AVG/DATE/TIME/AutoOFF, CAL1P/2P/°C, °F/dew point (°C,°F)/absolute humidity (g/m ³)/relative humidity (%)/display illumination	
Temperature	Principle	NTC	
	Measuring range	-20 ... 50 °C	
	Accuracy	±0.3 °C (0 ... 40 °C), otherwise ±0.5 °C, + 1 Digit	
Relative humidity	Principle	NTC	
	Measuring range	0 ... 98 % RH	
	Accuracy	±2 % RH, + 1 Digit	
Dew point	Measuring range	-50 ... 50 °C	
	Unit	°C	
	Accessories	Carrying case for device and accessories	3120.CAS
	Calibration solution 35% RH	5120.035	
	Calibration solution 50% RH	5120.050	
	Calibration solution 80% RH	5120.080	
	Metal grid filter for medium dirt protection	5120.210	
	Stainless steel sinter filter for high dirt protection	5120.211	
	Robust calibration block	5120.KAL	



Hand-Held Device C210 Temperature/Humidity			Order No.
<p><i>Thermo-hygrometer with flexible probe. Application area: climate monitoring in buildings; climate control in ventilation ducts, control cabinets, storerooms and museums; dew point calculation; calculation of absolute humidity. Excellent readability, illuminated display, Hold, MAX, MIN, Average value, automatic switch-off function, single point calibration (temperature), double point calibration (RH), THUMB-WHEEL operation, real-time clock, °C/°F switchable.</i></p>			
Hand-Held Device C210			5120.10
Technical data	Dimensions	147 x 85 x 37 mm	
	Weight	Approx. 400g	
	Functions	HOLD/MAX/MIN/AVG/DATE/TIME/AutoOFF, CAL1P/2P/°C, °F/dew point (°C,°F) /absolute humidity (g/m ³) /relative humidity (%) /display illumination	
Temperature	Principle	NTC	
	Measuring range	-20 ... 50 °C	
	Accuracy	±0.3 °C (0 ... 40 °C), otherwise ±0.5 °C, + 1 Digit	
Relative humidity	Principle	Capacitive	
	Measuring range	0 ... 98 % RH	
	Accuracy	±2 % RH, + 1 Digit	
Dew point	Measuring range	-50 ... 50 °C	
	Unit	°C	
	Accessories	Carrying case for device and accessories	3120.CAS
	Calibration solution 35% RH	5120.035	
	Calibration solution 50% RH	5120.050	
	Calibration solution 80% RH	5120.080	
	Metal grid filter for medium dirt protection	5120.210	
	Stainless steel sinter filter for high dirt protection	5120.211	
	Robust calibration block	5120.KAL	





C-Series

Precision Devices for Air Pressure and Differential Pressure



C300

Hand-Held Device C300 Pressure			Order No.
C300 Hand-Held Measuring Device for precise air pressure measurements.			2120.00
Technical data	Dimensions	147 x 85 x 37 mm	
	Weight	Approx. 400 g	
	Functions	HOLD/MAX/MIN/AVG/DATE/TIME/AutoOFF, CAL1P/hPa/mbar/inHg/psi/display illumination	
Pressure	Measuring range	300 ... 1200 hPa	
	Accuracy	±0.5 hPa at 25 °C / ±1.0 hPa for 0 °C < T < 50 °C, + 1 Digit	
	Resolution	0.1 hPa	
Accessories	Carrying case for device and accessories	3120.CAS	



C310, C320, C330, C340

Hand-Held Device C3xx Pressure			Order No.
C310, C320, C330, C340 Hand-Held Measuring Devices for precise differential pressure measurements.			
Technical data	Dimensions	147 x 85 x 37 mm	
	Weight	Approx. 400 g	
	Functions	HOLD/MAX/MIN/AVG/DATE/TIME/AutoOFF, CAL1P (ZERO)/2p/hPa, mbar, bar, psi/display illumination	
Differential pressure	Measuring medium	Non-aggressive gas	
	Principle	Piezoresistive	
	Accuracy	±0.8 % v. Measuring range/25 °C +/- 1 Digit	
	Resolution	0.1 %	
Hand-Held Device C310 (- 500 ... 500 Pa)			2120.10
Hand-Held Device C320 (- 0 ... 100 mbar [hPa])			2120.20
Hand-Held Device C330 (- 0 ... 2 bar)			2120.30
Hand-Held Device C340 (- 0 ... 5 bar)			2120.40
Accessories	Carrying case for device and accessories	3120.CAS	

Precision Digital Anemometer Flow Sensors



Hand-Held Device C400 Wind/Flow			Order No.
<p><i>Precision digital anemometer for air flow measurements in ventilation ducts and clean rooms. Excellent readability, illuminated display, Hold, MAX, MIN, Average value, automatic switch-off function, single point calibration (temperature), THUMB-WHEEL operation, real-time clock, °C/°F switchable.</i></p>			6120.00N
Technical data	Dimensions	147 x 85 x 37 mm	
	Functions	HOLD/MAX/MIN/AVG/DATE/TIME/AutoOFF, CAL, °C, °F/Display lighting/fpm/Pabs	
Flow	unit	m/s	
Temperature	Measuring range	0 ... 50 °C	
	Accuracy	± 0.7 °C within the range of 0 ... 50 °C	
Accessories	Carrying case for device and accessories		6120.CAS
	Extension cable for sensor, 2m		8152.KAB



Air Flow/Temperature Sensor (0...2m/s)			Order No.
<p>Combined Flow/Temperature Sensor 0...2 m/s.</p>			6120.51
Technical data	Dimensions	Length approx 200 mm, Ø 60 mm	
Flow	Measuring range	0 ... 2 m/s	
	Accuracy	20 °C, 45 % RH, 1013 hPa: ±(0.04 m/s + 1 % of value)	
Temperature	Measuring range	-20 ... 70 °C	
	Accuracy	± 0.7 °C within the range of 0 ... 50 °C and v > 0.5 m/s	

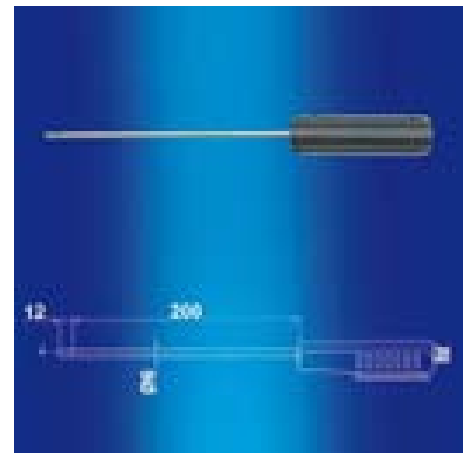

Air Flow/Temperature Sensor (0...20m/s)			Order No.
<p>Combined Flow/Temperature Sensor 0...20 m/s.</p>			6120.52
Technical data	Dimensions	Length 200 mm, Ø 6 mm	
Flow	Measuring range	0 ... 20 m/s	
	Accuracy	20 °C, 45 % RH, 1013 hPa: ±(0.2 m/s + 2 % of value)	
Temperature	Measuring range	-20 ... 70 °C	
	Accuracy	± 0.7 °C within the range of 0 ... 50 °C and v > 0.5 m/s	

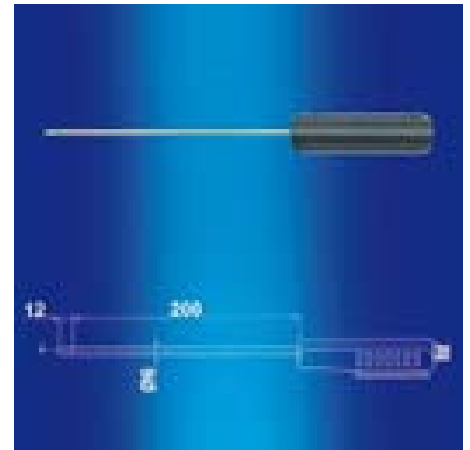

References

Bauschutz GmbH, Asperg
Form & Test, Riedlingen
Fischer Kältetechnik, Stuttgart
Raumluftverbesserungssysteme, Barsinghausen
Matzner Messgeräte, Munich
Horst Helmer, Muhr am See
Anderberg Fugtstyring, Denmark



Measurement



Storage and Transfer



Representation and Evaluation



Qualification and Calibration



Alarm

G. LUFFT
Mess- und Regeltechnik GmbH
Gutenbergstrasse 20
70736 Fellbach

Postfach 4252
70719 Fellbach

Tel. +49 (0)711-51 822-0
Fax +49 (0)711-51 822-41

www.lufft.de
info@lufft.de

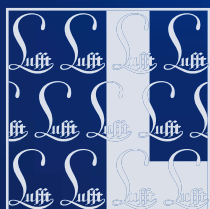

Lufft